

1. Consider a single mode field in a non-linear medium represented by the Hamiltonian:

$$\hat{H} = \hbar \left[ \omega \hat{a}^\dagger \hat{a} + \lambda (\hat{a}^\dagger \hat{a})^2 \right]$$

- (a) What is the time evolution of an initial coherent state,  $|\alpha\rangle$ , under the action of this Hamiltonian? (3 points)

As usual, we express  $|\alpha\rangle$  as a sum of Fock states:

$$\begin{aligned} |\alpha\rangle &= e^{-|\alpha|^2/2} \sum_{n=0}^{\infty} \frac{\alpha^n}{\sqrt{n!}} |n\rangle \\ |\alpha, t\rangle &= e^{-i\hat{H}t/\hbar} |\alpha\rangle \\ &= e^{-|\alpha|^2/2} \sum_{n=0}^{\infty} \frac{\alpha^n}{\sqrt{n!}} e^{-it(\omega \hat{a}^\dagger \hat{a} + \lambda (\hat{a}^\dagger \hat{a})^2)} |n\rangle \\ &= e^{-|\alpha|^2/2} \sum_{n=0}^{\infty} \frac{\alpha^n}{\sqrt{n!}} e^{-i\omega n t} e^{-i\lambda n^2 t} |n\rangle \end{aligned}$$

- (b) Apart from the normal rotation of a coherent state, represented by the  $e^{-i\omega t}$  phase shift, is this state periodic? If so, what is the period? (If you like, let  $\omega \rightarrow 0$ ; this is equivalent to working in the interaction picture.) (3 points)

In the interaction picture:

$$|\alpha, t\rangle \rightarrow e^{-|\alpha|^2/2} \sum_{n=0}^{\infty} \frac{\alpha^n}{\sqrt{n!}} e^{-i\lambda n^2 t} |n\rangle$$

The only time dependent part is the  $e^{-i\lambda n^2 t}$  term. Each number state oscillates with a different frequency. However, as  $n^2$  is an integer, all the frequencies are harmonics of  $\omega_1 = \lambda$  (apart from the  $n = 0$  term, which is stationary). The period is thus:  $T = 2\pi/\lambda$ .

- (c) Express the state at a time  $t = \frac{\pi}{2\lambda}$  as a sum of two coherent states. What is this state, and is it classical? Hint: first consider states of even and odd  $n$  separately. (4 points)

Again we work in the interaction picture. At the given time:

$$\left| \alpha, t = \frac{\pi}{2\lambda} \right\rangle = e^{-|\alpha|^2/2} \sum_{n=0}^{\infty} \frac{\alpha^n}{\sqrt{n!}} e^{-i\pi n^2/2} |n\rangle$$

For an integer  $n$ , we find:

$$\begin{aligned} e^{-i\pi n^2/2} &= \begin{cases} 1 & n \text{ even} \\ -i & n \text{ odd} \end{cases} \\ &= \frac{1}{2} [1 + (-1)^n] + \frac{i}{2} [-1 + (-1)^n] \\ &= \frac{1-i}{2} + \frac{1+i}{2} (-1)^n \end{aligned}$$

Noting that the  $(-1)^n$  creates a  $|\alpha\rangle$  term, we can rewrite the state as a superposition of two coherent states:

$$\begin{aligned} \left| \alpha, t = \frac{\pi}{2\lambda} \right\rangle &= \frac{1-i}{2} |\alpha\rangle + \frac{1+i}{2} |-\alpha\rangle \\ &= \frac{1}{\sqrt{2}} \left( e^{-i\frac{\pi}{4}} |\alpha\rangle + e^{+i\frac{\pi}{4}} |-\alpha\rangle \right), \end{aligned}$$

which is a Schrödinger's Cat state with an extra phase shift on each of the terms. This state is clearly non-classical.

Note that including the  $e^{-i\omega t}$  terms just rotates  $\alpha$  in the complex plane:

$$\left| \alpha, t = \frac{\pi}{2\lambda} \right\rangle = \frac{1}{\sqrt{2}} \left( e^{-i\frac{\pi}{4}} |\alpha e^{i\frac{\pi\omega}{2\lambda}}\rangle + e^{+i\frac{\pi}{4}} |-\alpha e^{i\frac{\pi\omega}{2\lambda}}\rangle \right)$$

2. In real quantum optics experiments, it is important to consider the effects of photon loss due to imperfect mirrors, detectors, etc. This can be modeled by inserting a weakly reflecting beam splitter, where in the end we trace over the state  $|\Psi\rangle_{loss}$  in the beam splitter output which corresponds to the loss channel.

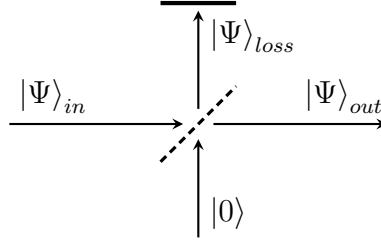

The loss “beam splitter” is represented in the usual way:

$$\begin{aligned} \hat{a}_{out} &= \cos \frac{\theta_L}{2} \hat{a}_{in} + i \sin \frac{\theta_L}{2} \hat{a}_0 \\ \hat{a}_{loss} &= i \sin \frac{\theta_L}{2} \hat{a}_{in} + \cos \frac{\theta_L}{2} \hat{a}_0, \end{aligned}$$

where  $\theta_L$  is the loss angle, which is related to the loss probability by  $L = \sin^2(\theta_L/2)$ . Consider the interaction-free measurement discussed in section 6.4 of Introductory Quantum Optics, but where one of the interferometer arms is lossy:

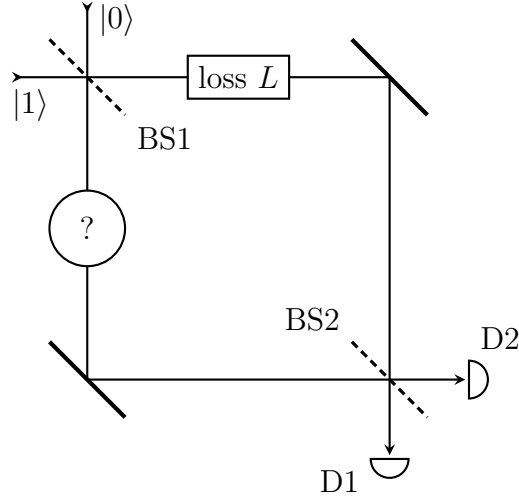

Assume BS1 and BS2 are normal 50:50 beam splitters.

- (a) What is the probability of a false object detection due to the lossy arm, or in other words what is the probability of finding a photon at D2 when no object is present? (4 points)

Inserting a loss “beam splitter” has the following effect:

$$\begin{aligned}
 |0\rangle |1\rangle &\xrightarrow{\text{loss}} \cos \frac{\theta_L}{2} |0\rangle |1\rangle |0\rangle_{\text{loss}} + i \sin \frac{\theta_L}{2} |0\rangle |0\rangle |1\rangle_{\text{loss}} \\
 |1\rangle |0\rangle &\xrightarrow{\text{loss}} |1\rangle |0\rangle |0\rangle_{\text{loss}},
 \end{aligned}$$

where we added a mode for the loss channel, which was previously assumed to be unpopulated. (We have also totally ignored the vacuum input to the “loss beamsplitter,” which is of course always unpopulated.)

Following 6.26-31 in the textbook:

$$\begin{aligned}
 |0\rangle |1\rangle &\xrightarrow{BS1} \frac{1}{\sqrt{2}} (|0\rangle |1\rangle + i |1\rangle |0\rangle) \\
 &\xrightarrow{\text{loss}} \frac{1}{\sqrt{2}} \left( \cos \frac{\theta_L}{2} |0\rangle |1\rangle |0\rangle_{\text{loss}} + i \sin \frac{\theta_L}{2} |0\rangle |0\rangle |1\rangle_{\text{loss}} + i |1\rangle |0\rangle |0\rangle_{\text{loss}} \right) \\
 &\xrightarrow{BS2} \frac{1}{2} \left[ \cos \frac{\theta_L}{2} (|0\rangle |1\rangle + i |1\rangle |0\rangle) + i (|1\rangle |0\rangle + i |0\rangle |1\rangle) \right] \times |0\rangle_{\text{loss}} + \\
 &\quad \frac{i \sin \frac{\theta_L}{2}}{\sqrt{2}} |0\rangle |0\rangle |1\rangle_{\text{loss}} \\
 &= \frac{1}{2} \left[ \left( \cos \frac{\theta_L}{2} - 1 \right) |0\rangle |1\rangle + i \left( \cos \frac{\theta_L}{2} + 1 \right) |1\rangle |0\rangle \right] \times |0\rangle_{\text{loss}} + \frac{i \sin \frac{\theta_L}{2}}{\sqrt{2}} |0\rangle |0\rangle |1\rangle_{\text{loss}}
 \end{aligned}$$

Obviously the loss mode never results in a photon at the detectors, and thus the false

positive probability is given by:

$$\begin{aligned}
 P(D2) &= \frac{1}{4} \left( \cos \frac{\theta_L}{2} - 1 \right)^2 \\
 &= \frac{1}{4} \left( \sqrt{1-L} - 1 \right)^2 \\
 &\approx \frac{L^2}{16} \text{ for } L \ll 1.
 \end{aligned}$$

- (b) *What is the probability of detecting a photon at D2 when an object is present? (3 points)*

There is no interference between the two paths because one is blocked and so we can treat the beamsplitters semi-classically. We lose half the photons at the first beam splitter, a fraction  $L$  in the lossy arm and another half at the final beam splitter. Thus:

$$\begin{aligned}
 P(D2, \text{object}) &= \frac{1-L}{4} \\
 &= \frac{1}{4} \cos^2 \frac{\theta_L}{2}
 \end{aligned}$$

- (c) *Consider a simpler loss model where we simply block the lossy arm completely in a fraction of the trials, with the fraction given by the loss probability  $L$ . In this case, what is the probability of finding a photon at D2 with and without the object in the non lossy arm? Is this the same as (a) and (b) above? (3 points)*

If we block the lossy arm and no object is present, the probability of detecting a photon at D2 is clearly  $\frac{1}{4}$ , and so in this model the false positive probability is:

$$\begin{aligned}
 P'(D2, \text{object}) &= \frac{L}{4} \\
 &= \frac{1}{4} \sin^2 \frac{\theta_L}{2}
 \end{aligned}$$

This is quite different from the correct result!

When the object is present, there is no interference and we can follow the same logic in part (b). We thus get the same probability of a detection event:

$$\begin{aligned}
 P'(D2, \text{object}) &= \frac{1-L}{4} \\
 &= \frac{1}{4} \cos^2 \frac{\theta_L}{2}
 \end{aligned}$$

This may be surprising, but it be explained by considering what happens when a photon is *not* lost. In this case we have gained some information about which path the photon took – namely it has a higher probability of being in the object arm. This unbalances the interference, resulting in some false counts. In fact, adding an identical loss to the object arm cancels the false counts!

3. Consider an effective Jaynes-Cummings model for a  $k$ -photon resonant interaction:

$$\hat{H}_{eff} = \hbar\lambda (\hat{a}^k \hat{\sigma}_+ + \hat{a}^{\dagger k} \hat{\sigma}_-),$$

where  $k$  is a positive integer. (Ignore the field and atom Hamiltonians,  $\hat{H}_A$  and  $\hat{H}_F$ , and consider only the interaction terms.) Note that the  $k = 1, 2$  cases were covered in the lectures and homework.

(a) What are the dressed states for this system? (3 points)

The Hamiltonian creates or destroys  $k$  photons to change the atom state, so clearly the transitions are of the form:

$$|e\rangle |n\rangle \leftrightarrow |g\rangle |n+k\rangle$$

And so we define:

$$\begin{aligned} |e\rangle_n &\equiv |e\rangle |n\rangle \\ |g\rangle_n &\equiv |g\rangle |n+k\rangle \end{aligned}$$

Considering only these two states, the submatrix of the Hamiltonian analogous to 4.143 in the textbook is:

$$\hat{H}_n = \hbar \begin{bmatrix} 0 & \lambda_n \\ \lambda_n & 0 \end{bmatrix},$$

where we have defined  $\lambda_n$ :

$$\begin{aligned} \lambda_n &= \lambda \sqrt{(n+1)(n+2)\cdots(n+k)} \\ &= \lambda \sqrt{\frac{(n+k)!}{n!}} \end{aligned}$$

Finding the eigenvalues of the Hamiltonian gives the dressed states:

$$\begin{aligned} |\pm\rangle &= \frac{1}{\sqrt{2}} (|e\rangle_n \pm |g\rangle_n) \\ E_{\pm} &= \pm \hbar \lambda_n \end{aligned}$$

(b) If the atom is in an initial excited state, what is the atomic inversion as a function of time for some arbitrary photon state described by  $C_n$ ? (2 points)

With an initial excited state, we have:

$$\begin{aligned} |e\rangle_n &= \frac{1}{\sqrt{2}} (|+\rangle + |-\rangle) \\ |e, t\rangle_n &= \frac{1}{\sqrt{2}} (e^{-i\lambda_n t} |+\rangle + e^{+i\lambda_n t} |-\rangle) \\ &= \frac{e^{-i\lambda_n t}}{2} (|e\rangle_n + |g\rangle_n) + \frac{e^{+i\lambda_n t}}{2} (|e\rangle_n - |g\rangle_n) \\ &= \cos(\lambda_n t) |e\rangle_n - i \sin(\lambda_n t) |g\rangle_n \end{aligned}$$

From this it should be clear how to obtain the probabilities of the atom states for an arbitrary photon state:

$$\begin{aligned}
 P_e(t) &= \sum_{n=0}^{\infty} |C_n|^2 \cos^2(\lambda_n t) \\
 P_g(t) &= \sum_{n=0}^{\infty} |C_n|^2 \sin^2(\lambda_n t) \\
 W(t) &= P_e(t) - P_g(t) \\
 &= \sum_{n=0}^{\infty} |C_n|^2 (\cos^2(\lambda_n t) - \sin^2(\lambda_n t)) \\
 &= \sum_{n=0}^{\infty} |C_n|^2 \cos(2\lambda_n t)
 \end{aligned}$$

- (c) Obtain an approximate expression for the inversion revival and collapse times for a coherent light field in the limit  $\bar{n} \gg k$ . (You do **not** need to do the expansion along the lines of 4.130-136 in Introductory Quantum Optics.) (2 points)

The Rabi frequency for this Hamiltonian is:

$$\begin{aligned}
 \Omega(n) &= 2\lambda \sqrt{\frac{(n+k)!}{n!}} \\
 &\cong 2\lambda n^{\frac{k}{2}} \text{ for } n \gg k
 \end{aligned}$$

We follow 4.128-129 in the textbook to find the coherence time:

$$\begin{aligned}
 \Omega(\bar{n} \pm \bar{n}^{\frac{1}{2}}) &\cong 2\lambda (\bar{n} \pm \sqrt{\bar{n}})^{\frac{k}{2}} \\
 &= 2\lambda \bar{n}^{\frac{k}{2}} \left(1 \pm \frac{1}{\sqrt{\bar{n}}}\right)^{\frac{k}{2}} \\
 &\cong 2\lambda \bar{n}^{\frac{k}{2}} \left(1 \pm \frac{k}{2\sqrt{\bar{n}}}\right) \\
 &= 2\lambda \bar{n}^{\frac{k}{2}} \pm k\lambda \bar{n}^{\frac{k-1}{2}} \\
 t_c &\cong [\Omega(\bar{n} + \sqrt{\bar{n}}) - \Omega(\bar{n} - \sqrt{\bar{n}})]^{-1} \\
 t_c^{-1} &\cong 2k\lambda \bar{n}^{\frac{k-1}{2}}
 \end{aligned}$$

To find the revival times, we use 4.137:

$$\begin{aligned}
 t_R &= 2\pi m [\Omega(\bar{n} + 1) - \Omega(\bar{n})]^{-1} \\
 &\cong 2\pi m \left[ \frac{\partial}{\partial n} \Omega(n) \Big|_{n=\bar{n}} \right]^{-1} \\
 t_R &= m \frac{2\pi}{k\lambda} \bar{n}^{1-\frac{k}{2}},
 \end{aligned}$$

where  $m = 0, 1, 2, \dots$

- (d) *By ignoring the  $\hat{H}_A$  and  $\hat{H}_F$  terms (4.96-97 in the textbook) we are effectively considering a system that is “on-resonance”. What does “on-resonance” mean for the  $k$ -photon case? Why can't we ignore these terms when considering the system off-resonance? (3 points)*

For a  $k$  photon state, the detuning would be defined by:

$$\Delta = \omega_0 - k\omega,$$

where  $\omega_0$  is the atom transition energy, as usual. On-resonance means  $\Delta = 0$  or alternatively  $\omega_0 = k\omega$ , in which case  $|e\rangle_n$  and  $|g\rangle_n$  have the same energy.

Now consider the full system Hamiltonian, including  $\hat{H}_A$  and  $\hat{H}_F$ :

$$\begin{aligned} \hat{H}_n &= \hbar \begin{bmatrix} n\omega + \frac{1}{2}\omega_0 & \lambda_n \\ \lambda_n & (n+k)\omega - \frac{1}{2}\omega_0 \end{bmatrix} \\ &= \hbar \left( n + \frac{k}{2} \right) \omega \times \mathbb{I} + \hbar \begin{bmatrix} +\frac{\Delta}{2} & \lambda_n \\ \lambda_n & -\frac{\Delta}{2} \end{bmatrix} \end{aligned}$$

The  $\mathbb{I}$  term is the common energy of the states  $|e\rangle_n$  and  $|g\rangle_n$  – since this causes an equal dephasing rate in both states we can ignore it when considering the system dynamics. Thus as long as  $\Delta = 0$ , we can use the  $\hat{H}_{eff}$  above. When this is not the case,  $|e\rangle_n$  and  $|g\rangle_n$  dephase at a different rate; this relative dephasing affects the system dynamics and must be taken into account (you did this in the homework).

4(a)

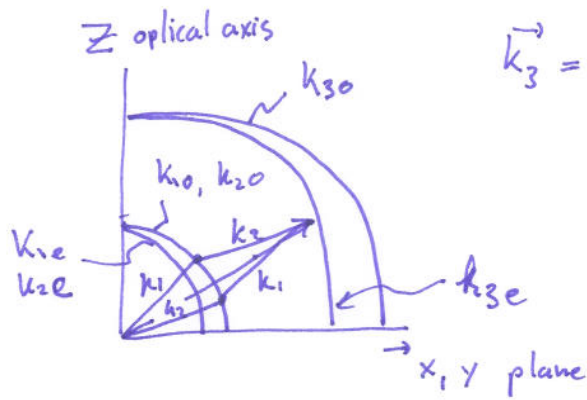

①  
 $O \equiv$  ordinary polarized, that is perpendicular to principle plane (plane defined by the crystal's optical axis and the pump  $k$  vector)  
 $e =$  in plane.

first look at type I noncollinear

$$\begin{matrix} k_1, k_2 \\ 0, 0 \end{matrix} \rightarrow \begin{matrix} k_3 \\ e \end{matrix}$$

$$\omega_3, k_3$$

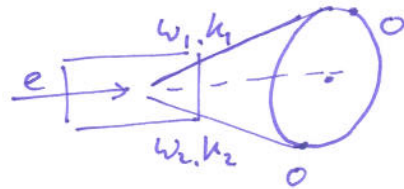

now look at type II noncollinear  $oe \rightarrow e$

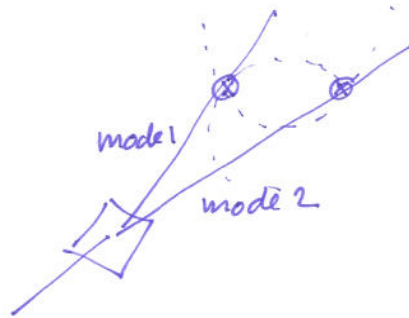
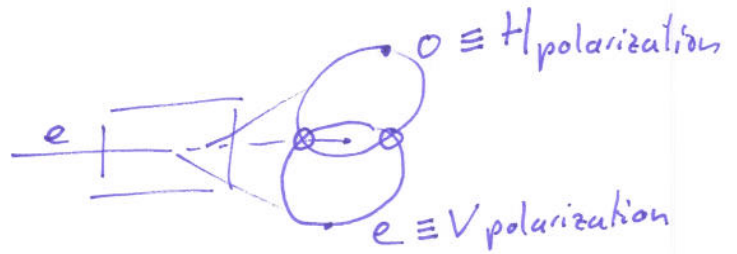
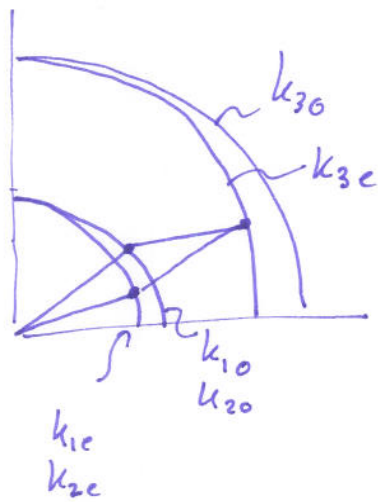

two possibilities to get photons in modes 1 and 2, either  $|H\rangle_1 |V\rangle_2$  or  $|V\rangle_1 |H\rangle_2$ . The two possibilities are indistinguishable (apart from polarization) and therefore form a quantum superposition

$$|H\rangle_1 |V\rangle_2 + e^{i\varphi} |V\rangle_1 |H\rangle_2$$

$\varphi$  can be tuned by birefringence in mode 1 or 2.

4(b) Go from V,H basis to arbitrary 2-dim orthon. basis  $\tilde{V}, \tilde{H}$  (2)

$$|\tilde{V}\rangle \equiv \alpha|V\rangle + \beta|H\rangle \quad |\alpha|^2 + |\beta|^2 = 1 \quad \alpha, \beta \in \mathbb{C}$$

$$|\tilde{H}\rangle \equiv \beta^*|V\rangle - \alpha^*|H\rangle$$

$$\text{inverse } \begin{cases} |V\rangle = \alpha|\tilde{V}\rangle + \beta|\tilde{H}\rangle \\ |H\rangle = \beta^*|\tilde{V}\rangle - \alpha|\tilde{H}\rangle \end{cases}$$

$$\begin{aligned} \frac{1}{\sqrt{2}} \{ |H\rangle_1 |V\rangle_2 - |V\rangle_1 |H\rangle_2 \} &= \frac{1}{\sqrt{2}} \{ (\beta^*|\tilde{V}\rangle - \alpha|\tilde{H}\rangle)_1 (\alpha|\tilde{V}\rangle + \beta|\tilde{H}\rangle)_2 - \\ &\quad (\alpha|\tilde{V}\rangle + \beta|\tilde{H}\rangle)_1 (\beta^*|\tilde{V}\rangle - \alpha|\tilde{H}\rangle)_2 \} = \\ &= \frac{1}{\sqrt{2}} \{ (\beta\beta^* + \alpha\alpha^*) |\tilde{V}\rangle_1 |\tilde{H}\rangle_2 - (\alpha\alpha^* + \beta\beta^*) |\tilde{H}\rangle_1 |\tilde{V}\rangle_2 \} = \\ &= \frac{1}{\sqrt{2}} \{ |\tilde{H}\rangle_1 |\tilde{V}\rangle_2 - |\tilde{V}\rangle_1 |\tilde{H}\rangle_2 \} \quad \text{up to an arbitrary phase factor.} \end{aligned}$$

for  $\psi_{12}^+$  we get several additional terms.

4(c) Construct instruction maps that are consistent with  $\psi_{12}^-$  properties and are local realistic (this means that the outcome of a measurement in mode 1 cannot be dependent on the choice of measurement in mode 2)

$A_1, B_1, C_1$  could have 8 possible outcomes

	$B_1$
$A_1$	$C_1$
+	+, +, +
+	+, +, -
:	:
-	-, -, -

+ means detection along  $\vec{a}$  (or  $\vec{b}$  or  $\vec{c}$ ) and  
- means detection along  $\vec{a}^\perp$  (or  $\vec{b}^\perp$  or  $\vec{c}^\perp$ )

they must correspond to  $A_2 B_2 C_2$  outcomes

-	-	-
-	-	+
:	:	:
+	+	+

in order to be consistent with  $\psi_{12}^-$  properties and local realism.

4(c) continue: The 8 combinations are equally likely to describe the detection features (in the  $A_1, B_1, C_1, A_2, B_2, C_2$  bases) for each emitted photon pair.

Consider now  $P(A_1^+, C_2^+)$ , the probability to detect a photon along  $\bar{a}$  in mode 1 and along  $\bar{c}$  in mode 2.

$(A_1^+, C_2^+)$  is consistent with  $(A_1, B_1, C_1, A_2, B_2, C_2)$   
 $(+, +, -, -, +)$   
 and  
 $(+, -, -, +, +)$

We now add two more measurement outcome combinations

$(+++; ---)$  and  $(---; +++)$

the four combinations together describe  $P(A_1^+, B_2^-)$   
and  $P(B_1^-, C_2^+)$

therefore  $P(A_1^+, C_2^+) < P(A_1^+, B_2^-) + P(B_1^-, C_2^+)$

However calculating the three probabilities via quantum mechanics we

find  $P(A_1^+, C_2^+) = (\frac{1}{2}\sqrt{3})^2$ , a  $A_1^+$  measurement implies that the photon in mode 2 is along  $\bar{a}$  which has a  $(\frac{1}{2}\sqrt{3})$  probability to be detected along  $\bar{c}$ .

$P(A_1^+, B_2^-) = (\frac{1}{2})^2$

$P(B_1^-, C_2^+) = (\frac{1}{2})^2$

$\frac{3}{4} \neq \frac{1}{4} + \frac{1}{4}$

! contradiction based on the probabilities (statistics) of certain measurement results.

4(d)

$$|H\rangle = \frac{1}{\sqrt{2}} (|H'\rangle - |V'\rangle) = \frac{i}{\sqrt{2}} (|L\rangle - |R\rangle)$$

$$|V\rangle = \frac{1}{\sqrt{2}} (|H'\rangle + |V'\rangle) = \frac{1}{\sqrt{2}} (|L\rangle + |R\rangle)$$

$$\psi_{123} = \frac{1}{\sqrt{2}} \{ |H\rangle_1 |H\rangle_2 |V\rangle_3 - |V\rangle_1 |V\rangle_2 |H\rangle_3 \}$$

in  $\beta_1 \beta_2 \alpha_3$  basis

$$= \frac{1}{4} \{ -( |L\rangle - |R\rangle )_1 ( |L\rangle - |R\rangle )_2 ( |H\rangle + |V\rangle )_3 - ( |L\rangle + |R\rangle )_1 ( |L\rangle + |R\rangle )_2 ( |H\rangle - |V\rangle )_3 \}$$

$$= \dots = \frac{1}{2} \{ - |L\rangle_1 |L\rangle_2 |H\rangle_3 + |L\rangle_1 |R\rangle_2 |V\rangle_3 + |R\rangle_1 |L\rangle_2 |V\rangle_3 - |R\rangle_1 |R\rangle_2 |H\rangle_3 \}$$

in  $\beta_1 \alpha_2 \beta_3$  basis

$$\psi_{123} = \dots = \frac{i}{2} \{ |L\rangle_1 |H'\rangle_2 |R\rangle_3 - |L\rangle_1 |V'\rangle_2 |L\rangle_3 - |R\rangle_1 |H'\rangle_2 |L\rangle_3 + |R\rangle_1 |V'\rangle_2 |R\rangle_3 \}$$

in  $\alpha_1 \beta_2 \beta_3$  basis

$$\psi_{123} = \dots = \frac{i}{2} \{ - |V\rangle_1 |L\rangle_2 |L\rangle_3 + |V\rangle_1 |R\rangle_2 |R\rangle_3 - |H'\rangle_1 |L\rangle_2 |R\rangle_3 + |H'\rangle_1 |R\rangle_2 |L\rangle_3 \}$$

4(e) Take first term from  $\beta_1 \beta_2 \alpha_3$  expression

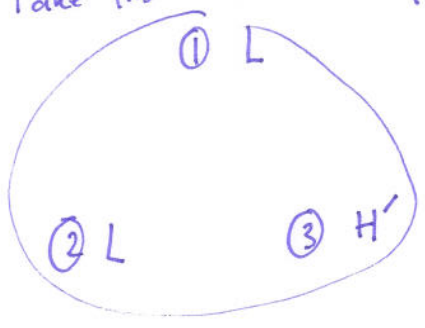

find  $\beta_1 \alpha_2 \beta_3$  expressions that are consistent with this

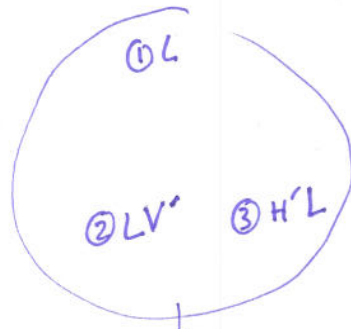
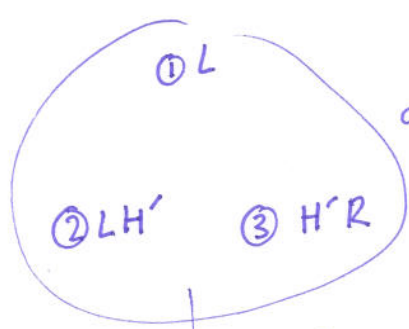

complete with  $\alpha_1 \beta_2 \beta_3$  measurement outcome

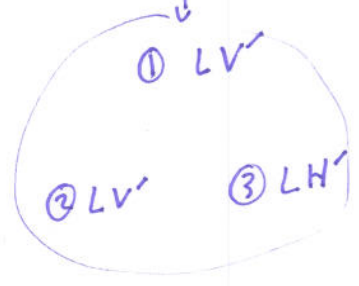
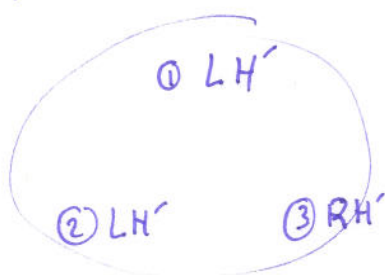

from this construction the possible  $\alpha_1 \alpha_2 \alpha_3$  outcomes are  $|H'\rangle_1 |H'\rangle_2 |H'\rangle_3$  and  $|V'\rangle_1 |V'\rangle_2 |H'\rangle_3$

Do this for all combinations and you find 4

possible outcomes for  $\alpha_1, \alpha_2, \alpha_3$  according to this "local realistic

construction:  $|H\rangle_1 |H\rangle_2 |H\rangle_3$ ,  $|V\rangle_1 |V\rangle_2 |H\rangle_3$ ,  $|H\rangle_1 |V\rangle_2 |V\rangle_3$ ,  $|V\rangle_1 |H\rangle_2 |V\rangle_3$

$$4(f) \quad \psi_{123} = \text{in } \alpha_1, \alpha_2, \alpha_3 \text{ basis} = \frac{1}{2} \left\{ |V\rangle_1 |V\rangle_2 |V\rangle_3 - |V\rangle_1 |H\rangle_2 |H\rangle_3 + |H\rangle_1 |H\rangle_2 |V\rangle_3 - |H\rangle_1 |V\rangle_2 |H\rangle_3 \right\}$$

(standard Q.M. calculation  
or in 4(d))

4(g)

Compare 4(e) and 4(f) and we see a complete contradiction. QM predicts  $\alpha_1, \alpha_2, \alpha_3$  outcomes that are impossible via a local hidden variable model and the other way around!